

## *Introduction and Precautions*

The following procedures cover adjustments that are not normally required once the transceiver has left the factory. However, if damage occurs and some parts subsequently be replaced, realignment may be required. If a sudden problem occurs during normal operation, it is likely due to component failure; re-alignment should not be done until after the faulty component has been replaced.

We recommend that servicing be performed by authorized Vertex Standard service technicians, experienced with the circuitry and fully equipped for repair and alignment. If a fault is suspected, contact the selling dealer for instructions regarding repair. Authorized Vertex Standard service technicians have the latest configuration information, and realign all circuits and make complete performance checks to ensure compliance with factory specifications after repairs.

Those who do undertake any of the following alignments are cautioned to proceed at their own risk. Problems caused by unauthorized attempts at re-alignment are not covered by the warranty policy. Also, Vertex Standard must reserve the right to change circuits and alignment procedures in the interest of improved performance, without notifying owners.

Under no circumstances should any alignment be attempted unless the normal function and operation of the transceiver are clearly understood, the cause of the malfunction has been clearly pinpointed and any faulty components replaced, and the need for realignment determined to be absolutely necessary.

The following test equipment (and thorough familiarity with its correct use) is necessary for complete realignment. Most steps do not require all of the equipment listed, but the interactions of some adjustments may require that more complex adjustments be performed in a sequence. Do not attempt to perform only a single step unless it is clearly isolated electrically from all other steps. Rather, have all test equipment ready before beginning, and follow all of the steps in a section in the order they are presented.

## *Required Test Equipment*

- RF Signal Generator
- AF Signal Generator
- Spectrum Analyzer good to at least 1 GHz.
- Frequency Counter
- SINAD Meter
- RF Millivoltmeter
- Digital DC Voltmeter (high-Z, 1 M-Ohm/V)
- DC Voltmeter
- DC Ammeter (20 A)
- Ohmmeter
- DMU-2000 Data Management Unit
- 50-Ohm Dummy Load (100 watts)
- 100-Ohm Dummy Load (100 watts)
- 150-Ohm Dummy Load (100 watts)
- In-Line Wattmeter (100 watts, 50-Ohm)
- Linear Detector
- RF Coupler
- 4-Ohm AF Dummy Load (3 watts)

## *Alignment Preparation & Precautions*

A 50-ohm RF Dummy load and in-line wattmeter must be connected to the "ANT 1" jack in all procedures that call for transmission, except where specified otherwise. Correct alignment is not possible with an antenna.

After completing one step, read the following step to determine whether the same test equipment will be required. If not, remove the test equipment (except dummy load and wattmeter, if connected) before proceeding.

Correct alignment requires that the ambient temperature be the same as that of the transceiver and test equipment, and that this temperature be held constant between 68 °F ~ 86 °F (20 °C ~ 30 °C). When the transceiver is brought into the shop from hot or cold air, it should be allowed time to come to room temperature before alignment.

Whenever possible, alignments should be made with oscillator shields and circuit boards firmly affixed in place. Also, the test equipment must be thoroughly warmed up before beginning.

**Note:** Signal levels in dB referred to in this procedure are based on 0 dB $\mu$  = 0.5  $\mu$ V (closed circuit).

# Alignment

## Analog Meter Adjustment

- ❑ Press and hold in the [1(1.8)], [2(3.5)], and [3(7)] keys, while turning the radio on, to enter the alignment mode.
- ❑ Rotate the Main Tuning Dial knob to select the alignment parameter “A01 FSC.”
- ❑ Rotate the [SUB(VFO-B)] knob so that the Main S-meter deflects to full scale.
- ❑ Press and hold in the [MENU] button for 2 seconds to save the new setting and exit from the alignment mode.

## SHIFT/WIDTH Knob

### Zero (Center) Adjustment

- ❑ Set the SHIFT/WIDTH knobs to the 12-o’clock position.
- ❑ Set the operating mode to “USB.”
- ❑ Press and hold in the [1(1.8)], [2(3.5)], and [3(7)] keys, while turning the radio on, to enter the alignment mode.
- ❑ Rotate the Main Tuning Dial knob to select the alignment parameter “A02 Sft.”
- ❑ Rotate the [SUB(VFO-B)] knob so that the IF SHIFT frequency is set to “±0.00” on the external display. The center point (±0.00) is broad (17 points). Therefore, set the [SUB(VFO-B)] knob to the center of this broad range.
- ❑ Rotate the Main Tuning Dial knob to select the alignment parameter “A03 udt.”
- ❑ Rotate the [SUB(VFO-B)] knob so that the IF bandwidth is set to “2.4 kHz” on the external display. The IF bandwidth (2.4 kHz) is broad (24 points). Therefore, set the [SUB(VFO-B)] knob to the center of this broad range.
- ❑ Press and hold in the [MENU] button for 2 seconds to save the new setting and exit from the alignment mode.

## VDD Meter Adjustment

- ❑ Connect the DC voltmeter to pin 6 of J5402 on the PA-A Unit.
- ❑ Switch the external display to “SWR Monitor” page.
- ❑ Press and hold in the [1(1.8)], [2(3.5)], and [3(7)] keys, while turning the radio on, to enter the alignment mode.
- ❑ Rotate the Main Tuning Dial knob to select the alignment parameter “A04 vdd.”
- ❑ Press the [ENT] key, then rotate the [SUB(VFO-B)] knob so that the VDD meter (Main S-meter) reading is same as that on the DC voltmeter.
- ❑ Rotate the [VRF] knob so that the VDD meter (on the external display) reading is same as that on the DC voltmeter.
- ❑ Press and hold in the [MENU] button for 2 seconds to save the new setting and exit from the alignment mode.

## ID Meter Adjustment

- ❑ Connect the 50-Ohm Dummy Load and Wattmeter to the “ANT 1” Jack, then set the METER switch to the “ID” position.
- ❑ Remove the jumper wire from TP5031 and TP5032 on the PA-A Unit, then connect the DC ammeter (20-A range) between TP5031 (+) and TP5032 (-).
- ❑ Set the Main Band (VFO-A) frequency to 14.200 MHz in the CW mode, then set the [RF PWR] knob fully clockwise position.
- ❑ Press and hold in the [1(1.8)], [2(3.5)], and [3(7)] keys, while turning the radio on, to enter the alignment mode.
- ❑ Rotate the Main Tuning Dial knob to select the alignment parameter “d56 Idd.”
- ❑ Press the PTT switch, then rotate the [SUB(VFO-B)] knob so that the ID meter reading is same as that on the DC ammeter.
- ❑ Press the [ENT] key, then release the PTT switch.
- ❑ Press and hold in the [MENU] button for 2 seconds to save the new setting and exit from the alignment mode.
- ❑ Disconnect the DC ammeter, then re-connect the jumper wire between TP5031 and TP5032.

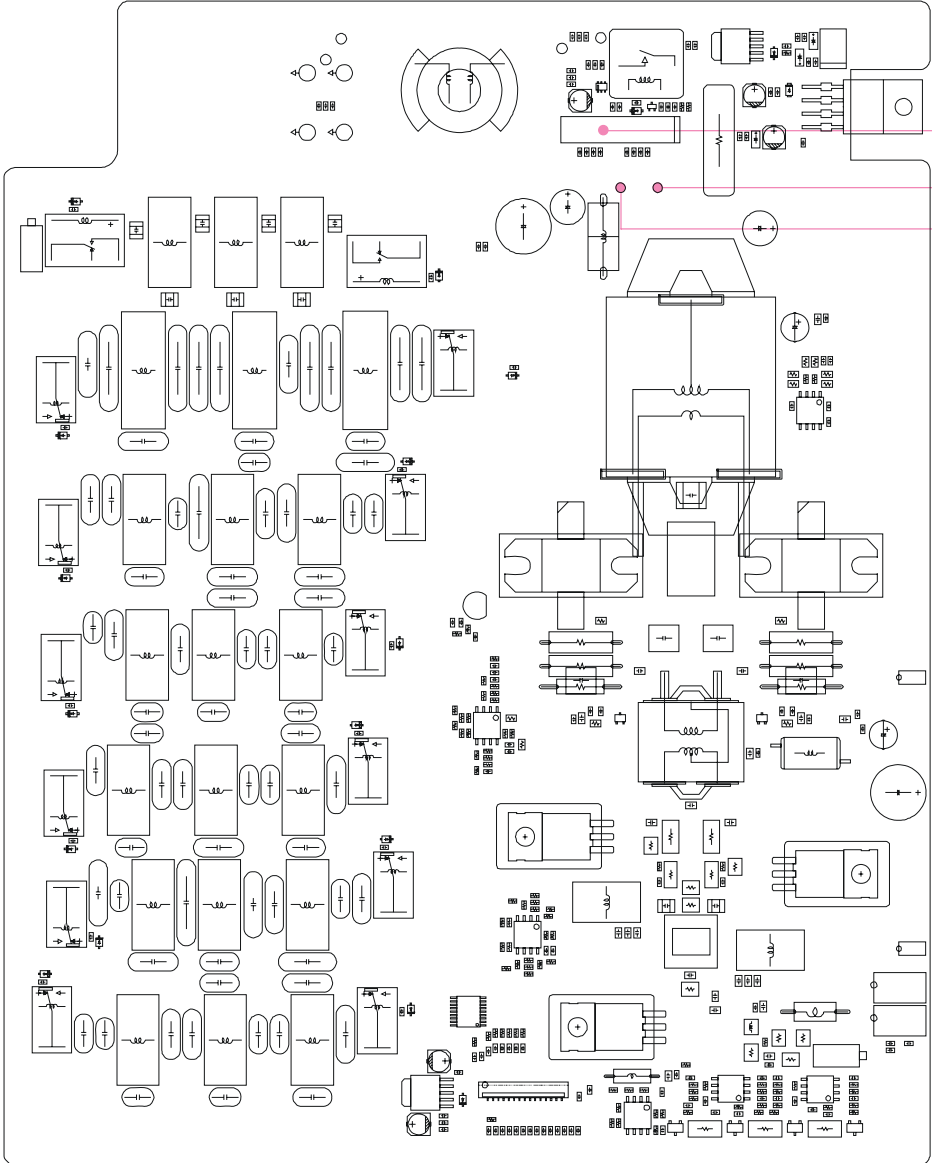

Pin 6 of J5042

TP5031

TP5032

**PA-A UNIT ALIGNMENT POINTS**

# Alignment

## 2nd Local Oscillator (Main) Adjustment

- ❑ Disconnect the coaxial cable from J4004 on the LOCAL Unit, then connect the Frequency counter to J4004.
- ❑ Press and hold in the [1(1.8)], [2(3.5)], and [3(7)] keys, while turning the radio on, to enter the alignment mode.
- ❑ Rotate the Main Tuning Dial knob to select the alignment parameter "A15 FrE."
- ❑ Rotate the [SUB(VFO-B)] knob so that the Frequency counter reading is "69.000 MHz."
- ❑ Press and hold in the [MENU] button for 2 seconds to save the new setting and exit from the alignment mode.
- ❑ Disconnect the Frequency counter from J4004, then connect the RF millivoltmeter to J4004.
- ❑ Adjust T4003 and T4004 on the LOCAL Unit for maximum deflection on the RF millivoltmeter (more than -5 dBm).
- ❑ Disconnect the RF millivoltmeter from J4004, then re-connect the coaxial cable to J4004.

## PLL (Main) Adjustment

- ❑ Connect the Digital DC voltmeter (high-Z) to TP4003 on the LOCAL Unit.
- ❑ Disconnect the coaxial cable from J4002 on the LOCAL Unit, then connect the RF millivoltmeter to J4002.

- ❑ Referring to the table below, adjust the listed components for the required voltage, or confirm that the correct voltage is present on each frequency listed.

VFO-A FREQUENCY	ADJUST / CONFIRM	DC VOLTMETER	RF MILLIVOLTMETER
11.495 MHz	Adjust TC4001	5.0 V ±0.1 V	At least +3 dBm
0.03 MHz	Confirm	At least 0.8 V	At least +3 dBm
25.495 MHz	Adjust TC4002	5.0 V ±0.1 V	At least +3 dBm
11.500 MHz	Confirm	At least 0.8 V	At least +3 dBm
41.495 MHz	Adjust TC4003	5.0 V ±0.1 V	At least +3 dBm
25.500 MHz	Confirm	At least 0.8 V	At least +3 dBm
60.000 MHz	Adjust TC4004	5.0 V ±0.1 V	At least +3 dBm
41.500 MHz	Confirm	At least 0.8 V	At least +3 dBm

- ❑ Disconnect the RF millivoltmeter from J4002, then re-connect the coaxial cable to J4002.

## PLL (Sub) Adjustment

- ❑ Connect the Digital DC voltmeter (high-Z) to TP4004 on the LOCAL Unit.
- ❑ Disconnect the coaxial cable from J4007 on the LOCAL Unit, then connect the RF millivoltmeter to J4007.
- ❑ Referring to the table below, adjust the listed components for the required voltage, or confirm that the correct voltage is present on each frequency listed.

VFO-B FREQUENCY	ADJUST / CONFIRM	DC VOLTMETER	RF MILLIVOLTMETER
11.495 MHz	Adjust TC4005	5.0 V ±0.1 V	At least +3 dBm
0.03 MHz	Confirm	At least 0.8 V	At least +3 dBm
25.495 MHz	Adjust TC4006	5.0 V ±0.1 V	At least +3 dBm
11.500 MHz	Confirm	At least 0.8 V	At least +3 dBm
41.495 MHz	Adjust TC4007	5.0 V ±0.1 V	At least +3 dBm
25.500 MHz	Confirm	At least 0.8 V	At least +3 dBm
60.000 MHz	Adjust TC4008	5.0 V ±0.1 V	At least +3 dBm
41.500 MHz	Confirm	At least 0.8 V	At least +3 dBm

- ❑ Disconnect the RF millivoltmeter from J4007, then re-connect the coaxial cable to J4007.

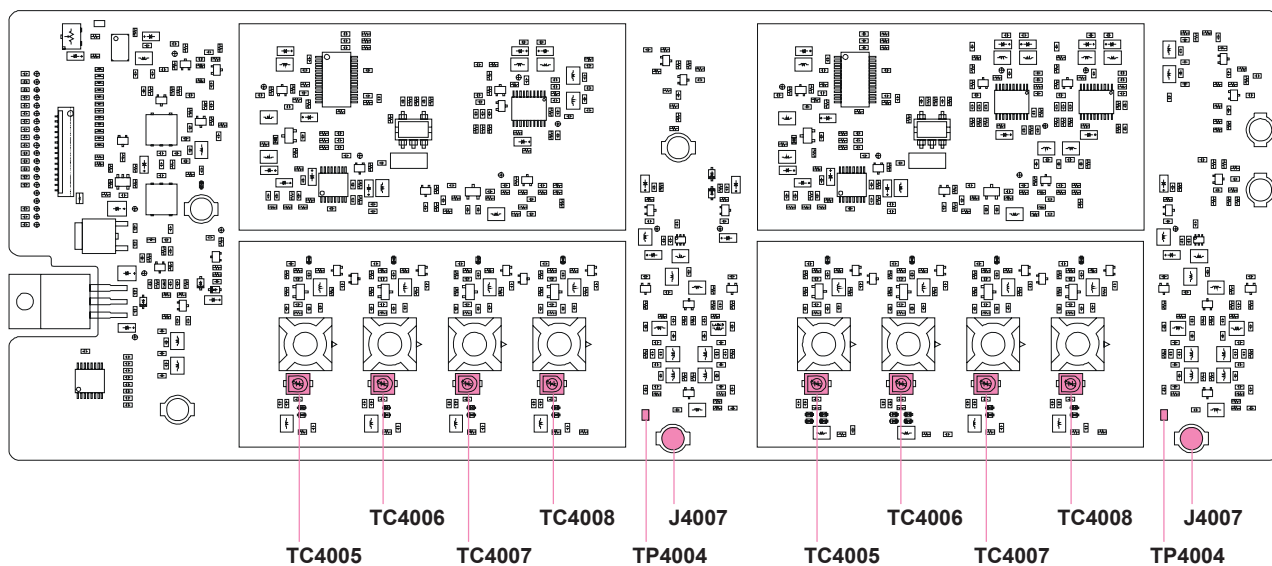

**PA-A UNIT ALIGNMENT POINTS**

## Main Receiver Adjustment

### 1st Local Oscillator Adjustment

- ❑ Set the following controls as indicated:  
 [IPO] button: AMP1  
 [ATT] button: OFF  
 [VRF] button: THRU  
 [R.FLT] button: AUTO  
 [AGC] button: AUTO  
 [RF GAIN] knob: Fully clockwise  
 [MODE] button: CW
- ❑ Connect the RF millivoltmeter to TP1073 on the MAIN Unit.
- ❑ Press and hold in the [1(1.8)], [2(3.5)], and [3(7)] keys, while turning the radio on, to enter the alignment mode.
- ❑ Select the appropriate “Alignment Parameter” using the Main Tuning Dial knob per the chart below, and adjust the [SUB(VFO-B)] knob for the corresponding RF millivoltmeter reading at each frequency.

ALIGNMENT PARAMETER	VFO-A FREQUENCY	RF MILLIVOLTMETER
A08 L18	1.850 MHz	0.96 Vrms (+0 Vrms/-0.04 Vrms)
A09 L35	3.570 MHz	0.96 Vrms (+0 Vrms/-0.04 Vrms)
A10 L7	7.100 MHz	0.96 Vrms (+0 Vrms/-0.04 Vrms)
A11 L14	14.200 MHz	0.84 Vrms (+0 Vrms/-0.04 Vrms)
A12 L21	21.200 MHz	0.84 Vrms (+0 Vrms/-0.04 Vrms)
A13 L28	28.700 MHz	0.84 Vrms (+0 Vrms/-0.04 Vrms)
A14 L50	51.500 MHz	0.5 Vrms (±0.05 Vrms)

- ❑ Press and hold in the [MENU] button for 2 seconds to save the new setting and exit from the alignment mode.

### 2nd/3rd Local Level Adjustment

- ❑ Connect the RF millivoltmeter to TP1021 on the MAIN Unit.
- ❑ Adjust T1034 on the MAIN Unit for maximum deflection on the RF millivoltmeter (more than +10 dBm).
- ❑ Connect the RF millivoltmeter to TP1018 on the MAIN Unit.
- ❑ Adjust T1028 on the MAIN Unit for maximum deflection on the RF millivoltmeter (more than +3 dBm).

### IF Transformer Adjustment

- ❑ Set the following controls as indicated:  
 [ANT 1/2] button: ANT 1  
 [IPO] button: AMP1  
 [ATT] button: OFF  
 [R.FLT] button: 15 kHz  
 [AGC] button: AUTO  
 [RF GAIN] knob: Fully clockwise  
 [VRF] button: THRU
- ❑ Set the Main Band (VFO-A) frequency to 14.200 MHz in the CW mode.
- ❑ Connect the AF millivoltmeter and 4 Ohm dummy load to the EXT SP jack.
- ❑ Connect the RF Signal Generator to the “ANT 1” jack, then set the output level to 0 dBμ at the 14.200 MHz.
- ❑ Adjust T1031, T1036, T1035, T1038, T1032, T1023, and T1019 on the MAIN Unit in succession several times for maximum deflection on the AF millivoltmeter.

When deflect the Main S-meter while adjustment, reduce the RF Signal Generator output so that the Main S-meter does not deflect.

### MCF Adjustment

- ❑ Set the following controls as indicated:  
 [ANT 1/2] button: ANT 1  
 [IPO] button: AMP1  
 [ATT] button: OFF  
 [AGC] button: AUTO  
 [RF GAIN] knob: Fully clockwise  
 [VRF] button: THRU
- ❑ Set the Main Band (VFO-A) frequency to 14.200 MHz in the CW mode.
- ❑ Connect the AF millivoltmeter, SINAD mater, and 4 Ohm dummy load to the EXT SP jack.
- ❑ Connect the RF Signal Generator to the “ANT 1” jack, then set the output level to 0 dBμ at the 14.200 MHz.
- ❑ Set the Roofing filter bandwidth to “3 kHz” by pressing the [R.FLT] button.
- ❑ Adjust TC1002 and T1040 on the MAIN Unit in succession several times for maximum deflection on the AF millivoltmeter.  
 When deflect the Main S-meter while adjustment, reduce the RF Signal Generator output so that the Main S-meter does not deflect.
- ❑ Set the Roofing filter bandwidth to “6 kHz” by pressing the [R.FLT] button.

# Alignment

- ❑ Adjust TC1001 and T1030 on the MAIN Unit in succession several times for maximum deflection on the AF millivoltmeter.  
When deflect the Main S-meter while adjustment, reduce the RF Signal Generator output so that the Main S-meter does not deflect.
- ❑ Set the Main Band (VFO-A) frequency to 50.000 MHz in the FM mode, and set the IPO to "AMP2" by pressing the [IPO] button.
- ❑ Set the Roofing filter bandwidth to "15 kHz" by pressing the [R.FLT] button, and set the IPO to "AMP2" by pressing the [IPO] button.
- ❑ Set the RF Signal Generator output to 0 dB $\mu$  at the 50.000 MHz.
- ❑ Adjust T1031 and T1036 on the MAIN Unit in succession several times for maximum deflection on the SINAD meter.  
When deflect the Main S-meter while adjustment, reduce the RF Signal Generator output so that the Main S-meter does not deflect.

## IF Trap Adjustment

- ❑ Set the following controls as indicated:  
[ANT 1/2] button: ANT 1  
[IPO] button: AMP1  
[ATT] button: OFF  
[R.FLT] button: AUTO  
[AGC] button: AUTO  
[RF GAIN] knob: Fully clockwise  
[VRF] button: THRU
- ❑ Set the Main Band (VFO-A) frequency to 50.000 MHz in the CW mode.
- ❑ Connect the AF millivoltmeter and 4 Ohm dummy load to the EXT SP jack.
- ❑ Connect the RF Signal Generator to the "ANT 1" jack, then set the output level to 60 dB $\mu$  at the 69.450 MHz.
- ❑ Adjust T1011 on the MAIN Unit for minimum deflection on the AF millivoltmeter.  
When deflect the Main S-meter while adjustment, reduce the RF Signal Generator output so that the Main S-meter does not deflect.

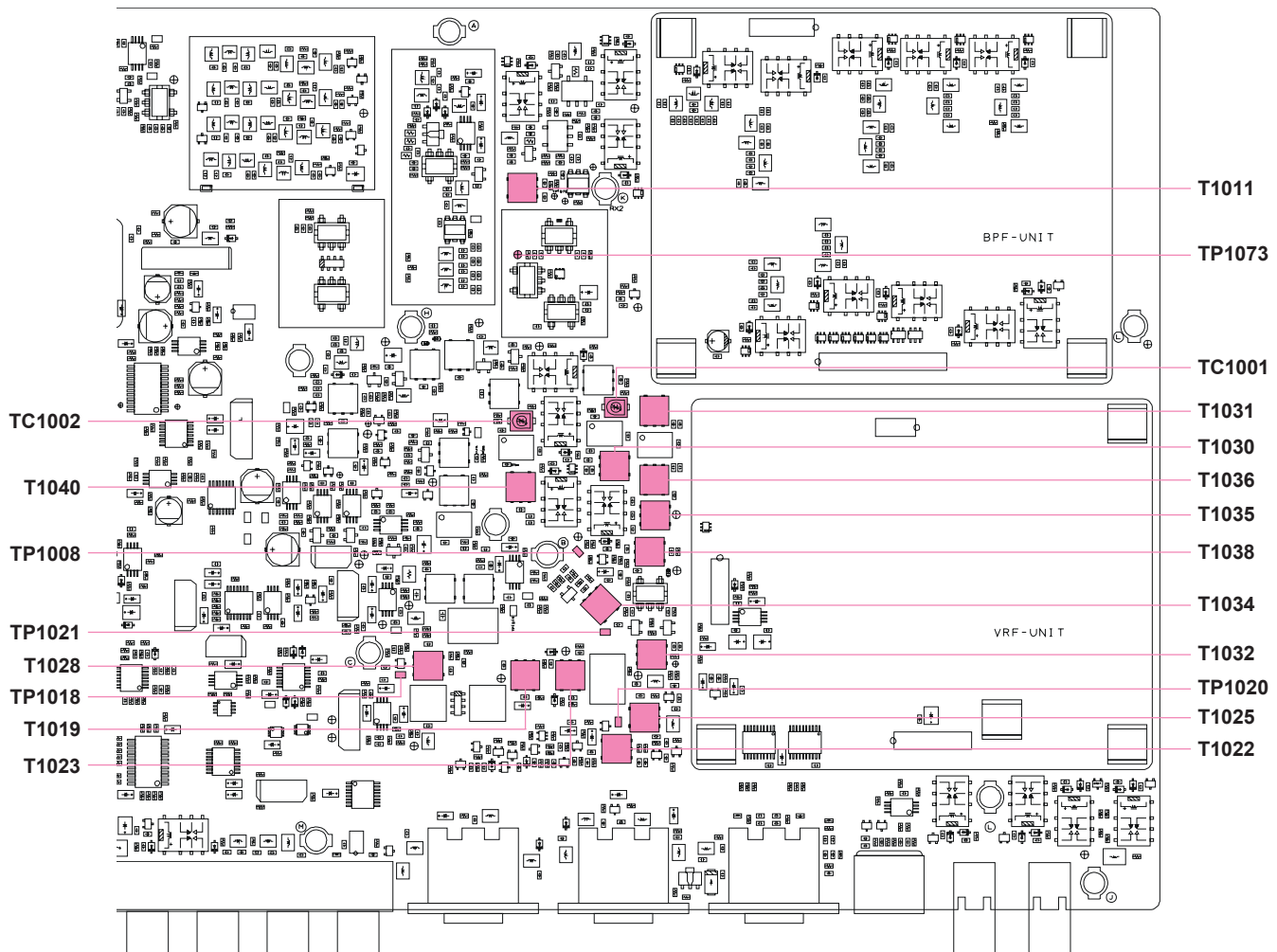

**MAIN UNIT (RECEIVER SECTION) ALIGNMENT POINTS**

## Noise Blanker Circuit Adjustment

- ❑ Set the following controls as indicated:
  - [ANT 1/2] button: ANT 1
  - [IPO] button: AMP1
  - [ATT] button: OFF
  - [R.FLT] button: AUTO
  - [AGC] button: AUTO
  - [NB] button: ON (for short-duration pulse noise)
  - [NB] knob: Fully clockwise
  - [RF GAIN] knob: Fully clockwise
  - [VRF] button: THRU
- ❑ Set the Main Band (VFO-A) frequency to 14.200 MHz in the CW mode.
- ❑ Connect the DC voltmeter to TP1020 on the MAIN Unit.
- ❑ Connect the RF Signal Generator to the “ANT 1” jack, then set the output level to 30 dB $\mu$  at the 14.200 MHz.
- ❑ Adjust T1025 and T1022 on the MAIN Unit for minimum deflection on the DC voltmeter.
- ❑ Turn the NB to “OFF” by pressing the [NB] button.

## Scope Circuit Adjustment

- ❑ Set the following controls as indicated:
  - [ANT 1/2] button: ANT 1
  - [IPO] button: AMP1
  - [ATT] button: OFF
  - [R.FLT] button: AUTO
  - [AGC] button: AUTO
  - [RF GAIN] knob: Fully clockwise
  - [VRF] button: THRU
- ❑ Set the Main Band (VFO-A) frequency to 14.200 MHz in the CW mode.
- ❑ Disconnect the coaxial cable from J1041 on the MAIN Unit, then connect the RF millivoltmeter to J1041.
- ❑ Connect the RF Signal Generator to the “ANT 1” jack, then set the output level to 90 dB $\mu$  at the 14.200 MHz.
- ❑ Adjust T1039 on the MAIN Unit for maximum deflection on the RF millivoltmeter.
- ❑ Disconnect the RF millivoltmeter from J1041, then re-connect the coaxial cable to J1041.

## RF AGC Adjustment

- ❑ Set the following controls as indicated:
  - [ANT 1/2] button: ANT 1
  - [IPO] button: AMP1
  - [ATT] button: OFF
  - [R.FLT] button: 6 kHz
  - [AGC] button: AUTO
  - [PITCH] knob: 800 Hz
  - [RF GAIN] knob: Fully clockwise
  - [VRF] button: THRU
  - [MODE] button: CW
- ❑ Connect the RF Signal Generator to the “ANT 1” jack, and connect the Digital DC voltmeter (high-Z) to TP1008 on the MAIN Unit.
- ❑ Press and hold in the [1(1.8)], [2(3.5)], and [3(7)] keys, while turning the radio on, to enter the alignment mode.
- ❑ Select the appropriate “Alignment Parameter” using the Main Tuning Dial knob per the chart below, then set the RF Signal Generator output to each listed, and adjust the [SUB(VFO-B)] knob for the corresponding DC voltmeter reading at each frequency.

ALIGNMENT PARAMETER	RF SIGNAL GENERATOR	VFO-A FREQUENCY	DC VOLTMETER
B01 rGc	1.900 MHz, 96 dB $\mu$	1.900 MHz	1.5 V (-0V/+0.05V)
B02 rGc	3.750 MHz, 96 dB $\mu$	3.750 MHz	1.5 V (-0V/+0.05V)
B03 rGc	7.150 MHz, 96 dB $\mu$	7.150 MHz	1.5 V (-0V/+0.05V)
B04 rGc	10.125 MHz, 96 dB $\mu$	10.125 MHz	1.5 V (-0V/+0.05V)
B05 rGc	14.175 MHz, 96 dB $\mu$	14.175 MHz	1.5 V (-0V/+0.05V)
B06 rGc	18.117 MHz, 96 dB $\mu$	18.117 MHz	1.5 V (-0V/+0.05V)
B07 rGc	21.255 MHz, 96 dB $\mu$	21.255 MHz	1.5 V (-0V/+0.05V)
B08 rGc	24.940 MHz, 96 dB $\mu$	24.940 MHz	1.5 V (-0V/+0.05V)
B09 rGc	28.850 MHz, 96 dB $\mu$	28.850 MHz	1.5 V (-0V/+0.05V)
B10 rGc	52.000 MHz, 96 dB $\mu$	52.000 MHz	1.5 V (-0V/+0.05V)

- ❑ Press and hold in the [MENU] button for 2 seconds to save the new setting and exit from the alignment mode.

# Alignment

## IF Gain Adjustment

- ❑ Set the following controls as indicated:
  - [ANT 1/2] button: ANT 1
  - [IPO] button: AMP1
  - [ATT] button: OFF
  - [R.FLT] button: 6 kHz
  - [AGC] button: AUTO
  - [PITCH] knob: 700 Hz
  - [RF GAIN] knob: Fully clockwise
  - [VRF] button: THRU
  - [MODE] button: CW
- ❑ Connect the AF millivoltmeter and 4 Ohm dummy load to the EXT SP jack.
- ❑ Connect the RF Signal Generator to the “ANT 1” jack, then set the output level to 36 dB $\mu$  at the 1.900 MHz.
- ❑ Set the Main Band (VFO-A) frequency to 1.900 MHz in the CW mode.
- ❑ Adjust the Main [AF GAIN] knob so that the AF millivoltmeter reading is “0 dB.”
- ❑ Press and hold in the [1(1.8)], [2(3.5)], and [3(7)] keys, while turning the radio on, to enter the alignment mode.
- ❑ Select the appropriate “Alignment Parameter” using the Main Tuning Dial knob per the chart below, then set the RF Signal Generator output to each listed, and adjust the [SUB(VFO-B)] knob for the corresponding AF millivoltmeter reading at each frequency.

ALIGNMENT PARAMETER	RF SIGNAL GENERATOR	VFO-A FREQUENCY	AF MILLIVOLTMETER
b11 iGn	1.900 MHz, 96 dB $\mu$	1.900 MHz	-1.5 dB ( $\pm 0.5$ dB)
b12 iGn	3.750 MHz, 96 dB $\mu$	3.750 MHz	-1.5 dB ( $\pm 0.5$ dB)
b13 iGn	7.150 MHz, 96 dB $\mu$	7.150 MHz	-1.5 dB ( $\pm 0.5$ dB)
b14 iGn	10.125 MHz, 96 dB $\mu$	10.125 MHz	-1.5 dB ( $\pm 0.5$ dB)
b15 iGn	14.175 MHz, 96 dB $\mu$	14.175 MHz	-1.5 dB ( $\pm 0.5$ dB)
b16 iGn	18.117 MHz, 96 dB $\mu$	18.117 MHz	-1.5 dB ( $\pm 0.5$ dB)
b17 iGn	21.255 MHz, 96 dB $\mu$	21.255 MHz	-1.5 dB ( $\pm 0.5$ dB)
b18 iGn	24.940 MHz, 96 dB $\mu$	24.940 MHz	-1.5 dB ( $\pm 0.5$ dB)
b19 iGn	28.850 MHz, 96 dB $\mu$	28.850 MHz	-1.5 dB ( $\pm 0.5$ dB)
b20 iGn	52.000 MHz, 96 dB $\mu$	52.000 MHz	-1.5 dB ( $\pm 0.5$ dB)

- ❑ Press and hold in the [MENU] button for 2 seconds to save the new setting and exit from the alignment mode.

## S-meter Adjustment

- ❑ Set the following controls as indicated:
  - [ANT 1/2] button: ANT 1
  - [IPO] button: AMP1
  - [ATT] button: OFF
  - [R.FLT] button: 6 kHz
  - [AGC] button: AUTO
  - [RF GAIN] knob: Fully clockwise
  - [VRF] button: THRU
- ❑ Connect the RF Signal Generator to the “ANT 1” jack, then set the frequency to 14.200 MHz.
- ❑ Set the Main Band (VFO-A) frequency to 14.200 MHz in the CW mode.
- ❑ Press and hold in the [1(1.8)], [2(3.5)], and [3(7)] keys, while turning the radio on, to enter the alignment mode.
- ❑ Select the appropriate “Alignment Parameter” using the Main Tuning Dial knob per the chart below, then set the RF Signal Generator output to each listed, and adjust the [SUB(VFO-B)] knob for the corresponding Main S-meter deflection, then press the [ENT] key to save the new setting at each frequency.

ALIGNMENT PARAMETER	RF SIGNAL GENERATOR	MAIN S-METER
B21 S-1	12 dB $\mu$	S-1
B22 S-5	24 dB $\mu$	S-5
B23 S-7	30 dB $\mu$	S-7
B24 S-9	36 dB $\mu$	S-9
B25 S10	46 dB $\mu$	S-9+10dB
B26 S20	56 dB $\mu$	S-9+20dB
B27 S30	66 dB $\mu$	S-9+30dB
B28 S40	76 dB $\mu$	S-9+40dB
B29 S50	86 dB $\mu$	S-9+50dB
B30 S60	96 dB $\mu$	S-9+60dB

- ❑ Press and hold in the [MENU] button for 2 seconds to save the new setting and exit from the alignment mode.

# Alignment

## FM Gain Adjustment

- ❑ Set the following controls as indicated:
  - [ANT 1/2] button: ANT 1
  - [IPO] button: AMP1
  - [ATT] button: OFF
  - [R.FLT] button: 15 kHz
  - [AGC] button: AUTO
  - [RF GAIN] knob: Fully clockwise
  - [VRF] button: THRU
- ❑ Set the RF Signal Generator to 12 dB $\mu$  at the 28.8500 MHz with  $\pm 3.5$  kHz deviation FM modulation of a 1 kHz audio signal.
- ❑ Set the Main Band (VFO-A) frequency to 28.850 MHz in the FM-W mode.
- ❑ Press and hold in the [1(1.8)], [2(3.5)], and [3(7)] keys, while turning the radio on, to enter the alignment mode.
- ❑ Rotate the Main Tuning Dial knob to select the alignment parameter "b32 FnG."
- ❑ Rotate the [SUB(VFO-B)] knob so that the Main S-meter reading is "S-3."
- ❑ Press and hold in the [MENU] button for 2 seconds to save the new setting and exit from the alignment mode.
- ❑ Set the RF Signal Generator to 12 dB $\mu$  at the 52.000 MHz with  $\pm 3.5$  kHz deviation FM modulation of a 1 kHz audio signal.

- ❑ Set the Main Band (VFO-A) frequency to 52.000 MHz in the FM-W mode.
- ❑ Press and hold in the [1(1.8)], [2(3.5)], and [3(7)] keys, while turning the radio on, to enter the alignment mode again.
- ❑ Rotate the Main Tuning Dial knob to select the alignment parameter "b33 FnG."
- ❑ Rotate the [SUB(VFO-B)] knob so that the Main S-meter reading is "S-3."
- ❑ Press and hold in the [MENU] button for 2 seconds to save the new setting and exit from the alignment mode.

## DVS Unit Adjustment

- ❑ Connect the Ohmmeter lead between TP2905 and ground on the DVS Unit.
- ❑ Adjust VR2901 on the DVS Unit for 40 k-Ohms ( $\pm 200$  Ohms) on the Ohmmeter.

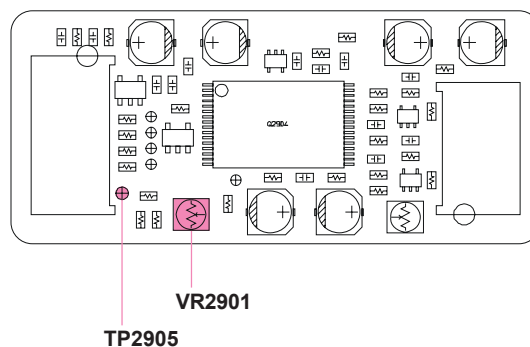

**DVS UNIT ALIGNMENT POINTS**

# Alignment

## Sub Receiver Adjustment

### 2nd/3rd Local Level Adjustment

- ❑ Set the following controls as indicated:
  - [ANT 1/2] button: ANT 1
  - [IPO] button: AMP1
  - [ATT] button: OFF
  - [AGC] button: AUTO
  - [RF GAIN] knob: Fully clockwise
  - [SUB RX] button: ON
- ❑ Connect the RF millivoltmeter to TP4501 on the RX-2 Unit.
- ❑ Adjust T4521 and T4501 on the RX-2 Unit for maximum deflection on the RF millivoltmeter (more than + 8 dBm).
- ❑ Connect the RF millivoltmeter to TP4502 on the RX-2 Unit.
- ❑ Adjust T4504 on the RX-2 Unit for maximum deflection on the RF millivoltmeter (more than + 6 dBm).

### IF Transformer Adjustment

- ❑ Set the following controls as indicated:
    - [ANT 1/2] button: ANT 1
    - [IPO] button: AMP1
    - [ATT] button: OFF
    - [AGC] button: AUTO
    - [RF GAIN] knob: Fully clockwise
    - [SUB RX] button: ON
  - ❑ Set the Sub Band (VFO-B) frequency to 14.200 MHz in the CW mode.
  - ❑ Connect the AF millivoltmeter and 4 Ohm dummy load to the EXT SP jack.
  - ❑ Connect the RF Signal Generator to the "ANT 1" jack, then set the output level to 0 dB $\mu$  at the 14.200 MHz.
  - ❑ Adjust T4507, T4509, T4511, T4515, T4517, T4518, T4519, T4516, T4513 and T4510 on the RX-2 Unit in succession several times for maximum deflection on the AF millivoltmeter.
- When deflect the Sub S-meter while adjustment, reduce the RF Signal Generator output so that the Sub S-meter does not deflect.

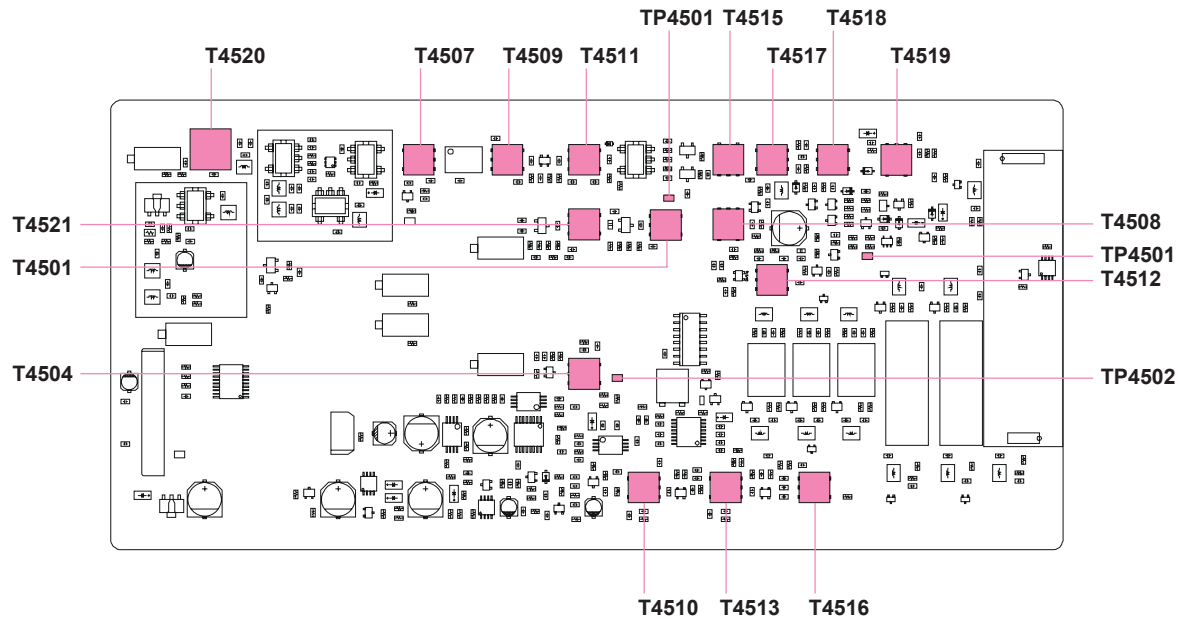

**RX-2 UNIT ALIGNMENT POINTS**

## MCF Adjustment

- ❑ Set the following controls as indicated:
  - [ANT 1/2] button: ANT 1
  - [IPO] button: AMP2
  - [ATT] button: OFF
  - [AGC] button: AUTO
  - [RF GAIN] knob: Fully clockwise
  - [SUB RX] button: ON
- ❑ Set the Sub Band (VFO-B) frequency to 52.000 MHz in the FM-W mode.
- ❑ Connect the SINAD meter and 4 Ohm dummy load to the EXT SP jack.
- ❑ Connect the RF Signal Generator to the “ANT 1” jack, then set the output level to 0 dB $\mu$  at the 52.000 MHz with  $\pm 3.5$  kHz deviation FM modulation of a 1 kHz audio signal.
- ❑ Adjust T4507 and T4509 on the RX-2 Unit in succession several times for maximum deflection on the SINAD meter.  
When deflect the Sub S-meter while adjustment, reduce the RF Signal Generator output so that the Sub S-meter does not deflect.

## IF Trap Adjustment

- ❑ Set the following controls as indicated:
  - [ANT 1/2] button: ANT 1
  - [IPO] button: AMP1
  - [ATT] button: OFF
  - [AGC] button: AUTO
  - [RF GAIN] knob: Fully clockwise
  - [SUB RX] button: ON
- ❑ Set the Sub Band (VFO-B) frequency to 50.000 MHz in the CW mode.
- ❑ Connect the AF millivoltmeter and 4 Ohm dummy load to the EXT SP jack.
- ❑ Connect the RF Signal Generator to the “ANT 1” jack, then set the output level to 60 dB $\mu$  at the 40.455 MHz.
- ❑ Adjust T4520 on the RX-2 Unit for minimum deflection on the AF millivoltmeter.  
When deflect the Sub S-meter while adjustment, reduce the RF Signal Generator output so that the Sub S-meter does not deflect.

## Noise Blanker Circuit Adjustment

- ❑ Set the following controls as indicated:
  - [ANT 1/2] button: ANT 1
  - [IPO] button: AMP1
  - [ATT] button: OFF
  - [AGC] button: AUTO
  - [NB] button: ON (for short-duration pulse noise)
  - [NB] knob: Fully clockwise
  - [RF GAIN] knob: Fully clockwise
  - [SUB RX] button: ON
- ❑ Set the Sub Band (VFO-B) frequency to 14.200 MHz in the CW mode.
- ❑ Connect the DC voltmeter to TP4505 on the RX-2 Unit.
- ❑ Connect the RF Signal Generator to the “ANT 1” jack, then set the output level to 30 dB $\mu$  at the 14.200 MHz.
- ❑ Adjust T4508 and T4512 on the MAIN Unit for minimum deflection on the DC voltmeter.
- ❑ Turn the NB to “OFF” by pressing the [NB] button.

## IF Gain Adjustment

- ❑ Set the following controls as indicated:
  - [ANT 1/2] button: ANT 1
  - [IPO] button: AMP1
  - [ATT] button: OFF
  - [AGC] button: AUTO
  - [PITCH] knob: 700 Hz
  - [RF GAIN] knob: Fully clockwise
  - [SUB RX] button: ON
- ❑ Connect the AF millivoltmeter and 4 Ohm dummy load to the EXT SP jack.
- ❑ Connect the RF Signal Generator to the “ANT 1” jack, then set the output level to 36 dB $\mu$  at the 1.900 MHz.
- ❑ Set the Sub Band (VFO-B) frequency to 1.900 MHz in the CW mode.
- ❑ Adjust the Sub [AF GAIN] knob so that the AF millivoltmeter reading is “0 dB.”
- ❑ Press and hold in the [1(1.8)], [2(3.5)], and [3(7)] keys, while turning the radio on, to enter the alignment mode.

# Alignment

- Select the appropriate “Alignment Parameter” using the Main Tuning Dial knob per the chart below, then set the RF Signal Generator output to each listed, and adjust the [SUB(VFO-B)] knob for the corresponding AF millivoltmeter reading at each frequency.

ALIGNMENT PARAMETER	RF SIGNAL GENERATOR	VFO-B FREQUENCY	AF MILLIVOLTMETER
C01 iGn	1.900 MHz, 96 dB $\mu$	1.900 MHz	-1.5 dB ( $\pm 0.5$ dB)
C02 iGn	3.750 MHz, 96 dB $\mu$	3.750 MHz	-1.5 dB ( $\pm 0.5$ dB)
C03 iGn	7.150 MHz, 96 dB $\mu$	7.150 MHz	-1.5 dB ( $\pm 0.5$ dB)
C04 iGn	10.125 MHz, 96 dB $\mu$	10.125 MHz	-1.5 dB ( $\pm 0.5$ dB)
C05 iGn	14.175 MHz, 96 dB $\mu$	14.175 MHz	-1.5 dB ( $\pm 0.5$ dB)
C06 iGn	18.117 MHz, 96 dB $\mu$	18.117 MHz	-1.5 dB ( $\pm 0.5$ dB)
C07 iGn	21.255 MHz, 96 dB $\mu$	21.255 MHz	-1.5 dB ( $\pm 0.5$ dB)
C08 iGn	24.940 MHz, 96 dB $\mu$	24.940 MHz	-1.5 dB ( $\pm 0.5$ dB)
C09 iGn	28.850 MHz, 96 dB $\mu$	28.850 MHz	-1.5 dB ( $\pm 0.5$ dB)
C10 iGn	52.000 MHz, 96 dB $\mu$	52.000 MHz	-1.5 dB ( $\pm 0.5$ dB)

- Press and hold in the [MENU] button for 2 seconds to save the new setting and exit from the alignment mode.

## S-meter Adjustment

- Set the following controls as indicated:  
[ANT 1/2] button: ANT 1  
[IPO] button: AMP1  
[ATT] button: OFF  
[AGC] button: AUTO  
[RF GAIN] knob: Fully clockwise  
[SUB RX] button: ON
- Connect the RF Signal Generator to the “ANT 1” jack, then set the frequency to 14.200 MHz.
- Set the Sub Band (VFO-B) frequency to 14.200 MHz in the CW mode.
- Press and hold in the [1(1.8)], [2(3.5)], and [3(7)] keys, while turning the radio on, to enter the alignment mode.
- Select the appropriate “Alignment Parameter” using the Main Tuning Dial knob per the chart below, then set the RF Signal Generator output to each listed, and adjust the [SUB(VFO-B)] knob for the corresponding Sub S-meter deflection, then press the [ENT] key to save the new setting at each frequency.

ALIGNMENT PARAMETER	RF SIGNAL GENERATOR	SUB S-METER
C11 S-0	0 dB $\mu$	One dot
C12 S-1	12 dB $\mu$	S-1
C13 S-5	24 dB $\mu$	S-5
C14 S-7	30 dB $\mu$	S-7
C15 S-9	36 dB $\mu$	S-9
C16 S10	46 dB $\mu$	S-9+10dB
C17 S20	56 dB $\mu$	S-9+20dB
C18 S30	66 dB $\mu$	S-9+30dB
C19 S40	76 dB $\mu$	S-9+40dB
C20 S50	86 dB $\mu$	S-9+50dB
C21 S60	96 dB $\mu$	S-9+60dB

- Press and hold in the [MENU] button for 2 seconds to save the new setting and exit from the alignment mode.

## RX Carrier Point Adjustment

- Set the following controls as indicated:  
[ANT 1/2] button: ANT 1  
[IPO] button: AMP1  
[ATT] button: OFF  
[AGC] button: AUTO  
[RF GAIN] knob: Fully clockwise  
[SUB RX] button: ON
- Connect the RF Signal Generator to the “ANT 1” jack, then set the frequency to 14.200 MHz.
- Connect the AF millivoltmeter, Frequency Counter, and 4 Ohm dummy load to the EXT SP jack.
- Set the Sub Band (VFO-B) frequency to 14.200 MHz in the CW mode.
- Press and hold in the [1(1.8)], [2(3.5)], and [3(7)] keys, while turning the radio on, to enter the alignment mode.
- Rotate the Main Tuning Dial knob to select the alignment parameter “C22 L-C.”
- Set the RF Generator frequency so that the Frequency counter reading is “1 kHz,” then adjust the Sub [AF GAIN] knob so that the AF millivoltmeter reading is “0 dB.”
- Set the RF Generator frequency so that the Frequency counter reading is “300 Hz.”
- Rotate the [SUB(VFO-B)] knob so that the AF millivoltmeter reading is “-6 dB ( $\pm 0.2$  dB).”
- Set the RF Generator frequency so that the Frequency counter reading is “2.6 kHz.”
- Confirm that the AF millivoltmeter reading is more than “-6 dB.”
- Rotate the Main Tuning Dial knob to select the alignment parameter “C23 U-C.”
- Set the RF Generator frequency so that the Frequency counter reading is “1 kHz,” then adjust the Sub [AF GAIN] knob so that the AF millivoltmeter reading is “0 dB.”
- Set the RF Generator frequency so that the Frequency counter reading is “300 Hz.”
- Rotate the [SUB(VFO-B)] knob so that the AF millivoltmeter reading is “-6 dB ( $\pm 0.2$  dB).”
- Set the RF Generator frequency so that the Frequency counter reading is “2.6 kHz.”
- Confirm that the AF millivoltmeter reading is more than “-6 dB.”
- Rotate the Main Tuning Dial knob to select the alignment parameter “C24 LnC.”
- Set the RF Generator frequency so that the Frequency counter reading is “1 kHz,” then adjust

the Sub [AF GAIN] knob so that the AF millivoltmeter reading is “0 dB.”

- ❑ Set the RF Generator frequency so that the Frequency counter reading is “600 Hz.”
- ❑ Rotate the [SUB(VFO-B)] knob so that the AF millivoltmeter reading is “-6 dB ( $\pm 0.2$  dB).”
- ❑ Rotate the Main Tuning Dial knob to select the alignment parameter “C25 UnC.”
- ❑ Set the RF Generator frequency so that the Frequency counter reading is “1 kHz,” then adjust the Sub [AF GAIN] knob so that the AF millivoltmeter reading is “0 dB.”
- ❑ Set the RF Generator frequency so that the Frequency counter reading is “600 Hz.”
- ❑ Rotate the [SUB(VFO-B)] knob so that the AF millivoltmeter reading is “-6 dB ( $\pm 0.2$  dB).”
- ❑ Press and hold in the [MENU] button for 2 seconds to save the new setting and exit from the alignment mode.

## Transmitter Adjustment

### TX IFT Adjustment

- ❑ Disconnect the coaxial cable from J1004 on the MAIN Unit, then connect the RF millivoltmeter to J1004.
- ❑ Set the Main Band (VFO-A) frequency to 14.200 MHz in the FM mode, then rotate the [RF PWR] knob to the fully clockwise position.
- ❑ Press the PTT button, adjust T1033, T1029, T1020, T1014, T1010, and T1007 for maximum deflection on the RF millivoltmeter.
- ❑ Release the PTT button.
- ❑ Disconnect the RF millivoltmeter from J1004, then re-connect the coaxial cable to J1004.

### TX MCF Adjustment

- ❑ Disconnect the coaxial cables from J1004, J1038, and J1039 on the MAIN Unit.
- ❑ Set the Main Band (VFO-A) frequency to 28.850 MHz in the USB mode, then rotate the [RF PWR] knob to the fully clockwise position.

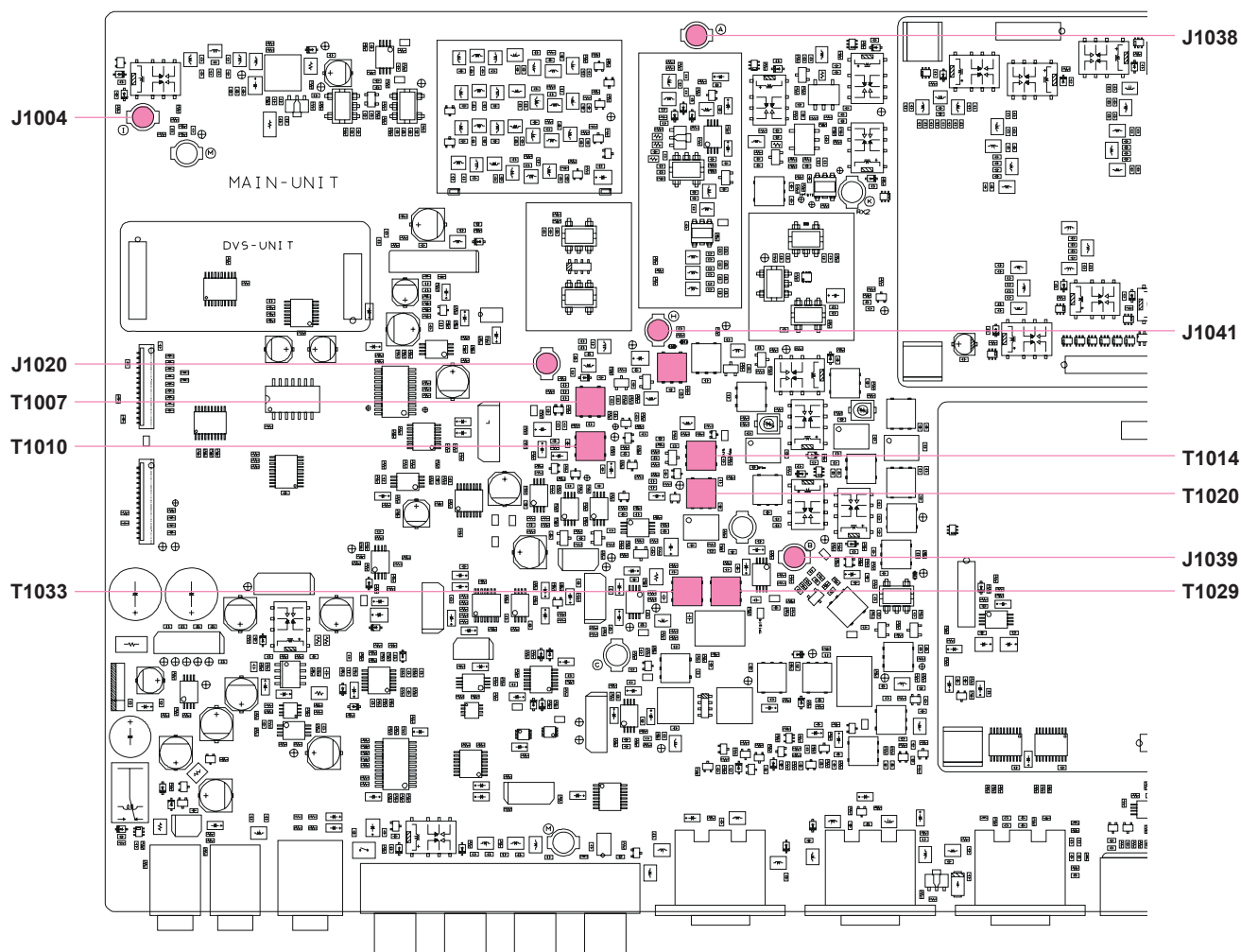

**MAIN UNIT (TRANSMITTER SECTION) ALIGNMENT POINTS**

# Alignment

- ❑ Connect the Tracking Generator to J1039 and connect the Spectrum Analyzer to J1020.
- ❑ Set up the Spectrum Analyzer as shown below:  
Center Frequency: 69.450 MHz  
Span: 50 kHz
- ❑ Press the PTT button, adjust T1020 on the TX Unit to obtain maximum amplitude with minimum ripple.
- ❑ Disconnect the Tracking Generator from J1039 and the Spectrum Analyzer from J1020.
- ❑ Connect the coaxial cables back to J1004, J1038, and J1039.

## TX Scope Circuit Adjustment

- ❑ Disconnect the coaxial cable from J1041 on the MAIN Unit, then connect the RF millivoltmeter to J1041.
- ❑ Disconnect the coaxial cable from J1004 on the MAIN Unit.
- ❑ Set the Main Band (VFO-A) frequency to 14.200 MHz in the CW mode, then rotate the [RF PWR] knob to the fully clockwise position.
- ❑ Press the PTT button, then adjust T1006 for maximum deflection on the RF millivoltmeter.
- ❑ Release the PTT button.
- ❑ Disconnect the RF millivoltmeter from J1041, then re-connect the coaxial cable to J1041.
- ❑ Re-connect the coaxial cable to J1004.

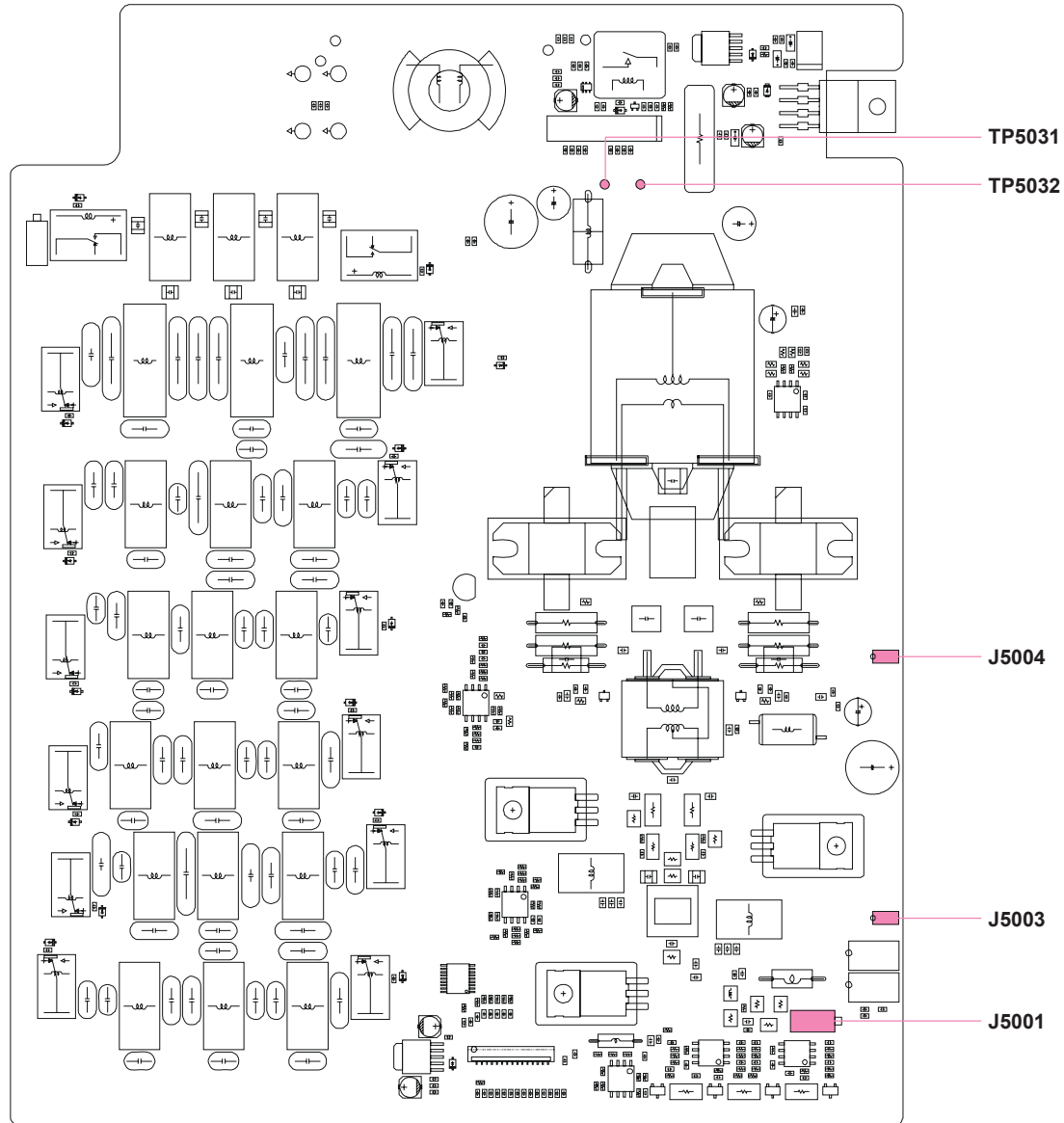

**PA-A UNIT ALIGNMENT POINTS**

## PA-A Unit Adjustment

### Preparation

- ❑ Disconnect the coaxial cables from J5001 and J5006 on the PA-A Unit, then terminate J5001 and J5006 into a 50-Ohm resistors.
- ❑ Disconnect the jumper plugs from J5003 and J5004 on the PA-A Unit, and remove the jumper wire which is connected between TP5031 and T5032 on the PA-B Unit.

### Pre-Drive Stage Idling Current Adjustment

- ❑ Connect the DC ammeter to J5003 on the PA-A Unit.
- ❑ Press and hold in the [1(1.8)], [2(3.5)], and [3(7)] keys, while turning the radio on, to enter the alignment mode.
- ❑ Rotate the Main Tuning Dial knob to select the alignment parameter "d01 Pdb."
- ❑ Press the PTT button, then adjust the [SUB(VFO-B)] knob so that the DC ammeter reading is "100 mA ( $\pm 50$  mA)."
- ❑ Release the PTT button.

### Drive Stage Idling Current Adjustment

- ❑ Release the PTT button.
- ❑ Connect the DC ammeter to J5004 on the PA-A Unit.
- ❑ Rotate the Main Tuning Dial knob to select the alignment parameter "d02 db1."
- ❑ Press the PTT button, then adjust the [SUB(VFO-B)] knob so that the DC ammeter reading is "500 mA ( $\pm 50$  mA)."
- ❑ Release the PTT button.
- ❑ Rotate the Main Tuning Dial knob to select the alignment parameter "d03 db2."
- ❑ Press the PTT button, then adjust the [SUB(VFO-B)] knob so that the DC ammeter reading is "500 mA ( $\pm 50$  mA)."
- ❑ Release the PTT button.

### Final Stage Idling Current Adjustment

- ❑ Connect the DC ammeter between TP5031 and TP5032 on the PA-A Unit.
- ❑ Rotate the Main Tuning Dial knob to select the alignment parameter "d04 Fb1."
- ❑ Press the PTT button, then adjust the [SUB(VFO-B)] knob so that the DC ammeter reading is "1 A ( $\pm 50$  mA)."
- ❑ Release the PTT button.
- ❑ Rotate the Main Tuning Dial knob to select the alignment parameter "d05 Fb2."
- ❑ Press the PTT button, then adjust the [SUB(VFO-B)] knob so that the DC ammeter reading is "1 A ( $\pm 50$  mA)."
- ❑ Release the PTT button.

### Termination

- ❑ Press and hold in the [MENU] button for 2 seconds to save the new setting and exit from the alignment mode.
- ❑ Disconnect the 50-Ohm resistors from J5001 and J5006, then connect the coaxial cables to J5001 and J5006.
- ❑ Re-connect the jumper plugs to J5003 and J5004, and re-connect the jumper wire between TP5031 and T5032.

# Alignment

## Antenna Tuner Adjustment

### CM Coupler Balance Adjustment

- ❑ Disconnect the coaxial cable from J6010 on the TUNER-MAIN Unit, then connect the 50-Ohm Dummy Load to J6010.
- ❑ Connect the Digital DC voltmeter (high-Z) to pin 3 of J6009 on the TUNER-MAIN Unit.
- ❑ Turn off the [TUNE] switch, then set the Main band (VFO-A) frequency to 24.900 MHz in the FM mode.
- ❑ Press the PTT switch, then rotate the [RF PWR] knob for 50 Watts on the Wattmeter.
- ❑ Adjust TC6002 on the TUNER-MAIN Unit for minimum deflection on the DC voltmeter (less than 0.1 V).
- ❑ Release the PTT switch, then disconnect the 50-Ohm Dummy Load from J6010 and re-connect the coaxial cable to J6010.

### $\phi$ , Z-Null Adjustment

- ❑ Connect the 50-Ohm Dummy Load and Wattmeter to the "ANT 1" jack.
- ❑ Turn off the [TUNE] switch, then set the Main Band (VFO-A) frequency to 24.900 MHz in the FM mode.
- ❑ Press the PTT switch, then rotate the [RF PWR] knob for 50 Watts on the Wattmeter.
- ❑ Release the PTT switch, then disconnect the coaxial cable from J6001 on the TUNER-MAIN Unit, and re-connect the 50-Ohm Dummy Load to J6001.
- ❑ Connect the Digital DC voltmeter (high-Z) between TP6001 and TP6002 on the TUNER-MAIN Unit, then turn on the [TUNE] switch.
- ❑ Press the PTT switch, then adjust TC6001 on the TUNER-MAIN Unit for 0 V ( $\pm 0.08$  V) on the DC voltmeter.
- ❑ Release the PTT switch, then disconnect the 50-Ohm Dummy Load from J6001 and re-connect the coaxial cable to J6001.

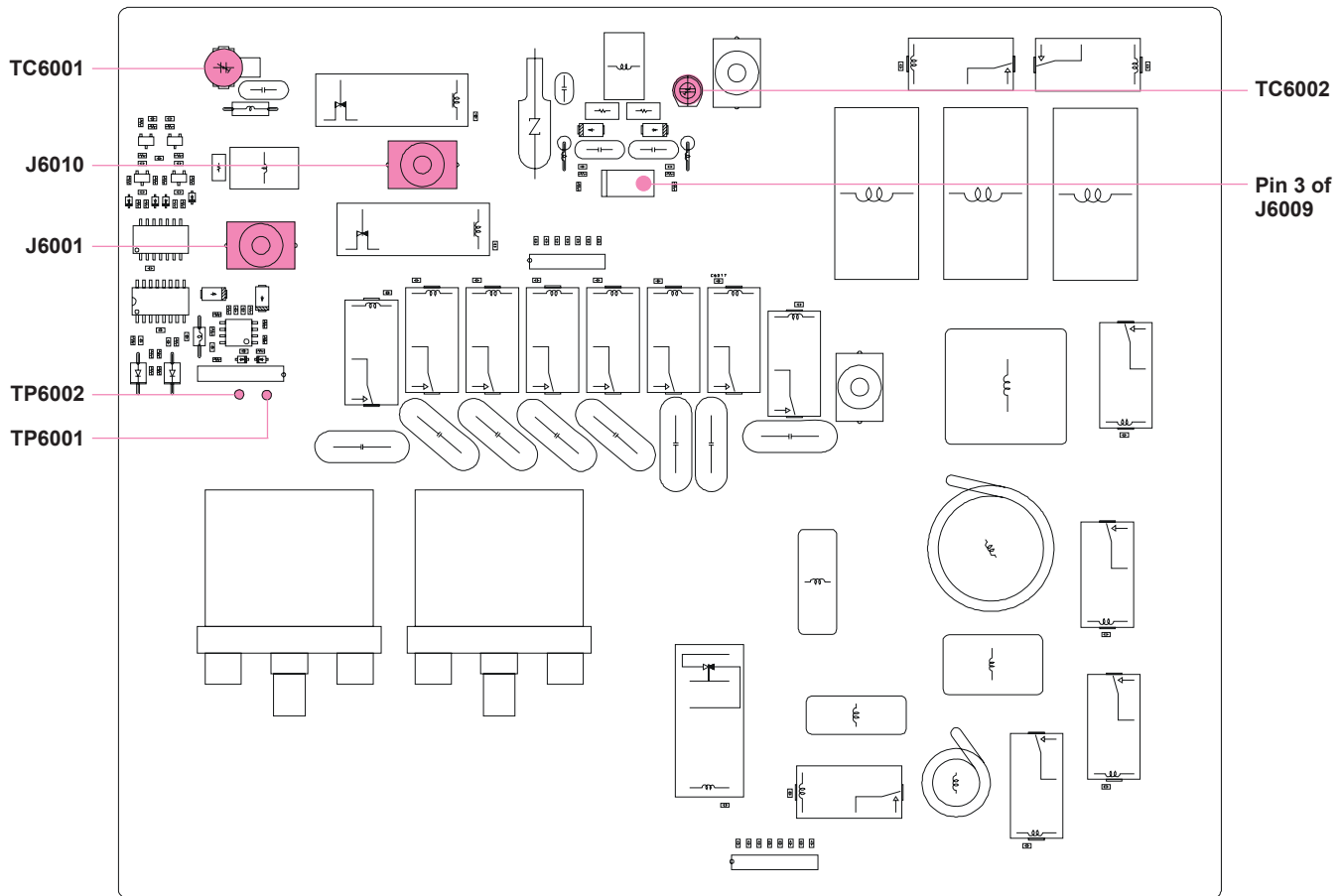

**TUNER-MAIN UNIT ALIGNMENT POINTS**

## Transmitter Section Alignment Mode

### Preparation

- ❑ Referring to table below, tune the Main Band (VFO-A) to each frequency listed.

BAND	VFO-A FREQUENCY	MODE
1.8 MHz Band	1.820 MHz	USB
3.5 MHz Band	3.570 MHz	USB
7 MHz Band	7.050 MHz	USB
10 MHz Band	10.100 MHz	USB
14 MHz Band	14.200 MHz	USB
18 MHz Band	18.100 MHz	USB
21 MHz Band	21.200 MHz	USB
24.5 MHz Band	24.900 MHz	USB
28 MHz Band	29.690 MHz	USB
50 MHz Band	53.900 MHz	USB

- ❑ Connect the 50-Ohm Dummy Load and Wattmeter to the "ANT 1" jack.
- ❑ Connect the Audio Generator to pin 8 of the MIC jack (pin 7: GND), then set the output level to 0.5 mV @1 kHz.

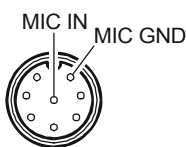

### ALC Adjustment

- ❑ Press and hold in the [1(1.8)], [2(3.5)], and [3(7)] keys, while turning the radio on, to enter the alignment mode.
- ❑ Rotate the Main Tuning Dial knob to select the alignment parameter "d08 iAL" then rotate the [SUB(VFO-B)] knob so that the VFO-B frequency display shows "0020."
- ❑ Rotate the [MIC] knob to the fully counter-clockwise position.
- ❑ Press the PTT switch, then gently rotate the [MIC] knob to the fully clockwise position.
- ❑ Rotate the [SUB(VFO-B)] knob for 115 W (+5W/-0W) on the Wattmeter.
- ❑ Release the PTT switch.
- ❑ Rotate the Main Tuning Dial knob to select the alignment parameter "d09 iAL" then rotate the [SUB(VFO-B)] knob so that the VFO-B frequency display shows "0020."
- ❑ Rotate the [MIC] knob to the fully counter-clockwise position.
- ❑ Press the PTT switch, then gently rotate the [MIC] knob to the fully clockwise position.
- ❑ Rotate the [SUB(VFO-B)] knob for 115 W (+5W/-0W) on the Wattmeter.
- ❑ Release the PTT switch.
- ❑ Rotate the Main Tuning Dial knob to select the alignment parameter "d10 iAL" then rotate the [SUB(VFO-B)] knob so that the VFO-B frequency display shows "0020."
- ❑ Rotate the [MIC] knob to the fully counter-clockwise position.

- ❑ Press the PTT switch, then gently rotate the [MIC] knob to the fully clockwise position.
- ❑ Rotate the [SUB(VFO-B)] knob for 115 W (+5W/-0W) on the Wattmeter.
- ❑ Release the PTT switch.
- ❑ Rotate the Main Tuning Dial knob to select the alignment parameter "d11 iAL" then rotate the [SUB(VFO-B)] knob so that the VFO-B frequency display shows "0020."
- ❑ Rotate the [MIC] knob to the fully counter-clockwise position.
- ❑ Press the PTT switch, then gently rotate the [MIC] knob to the fully clockwise position.
- ❑ Rotate the [SUB(VFO-B)] knob for 115 W (+5W/-0W) on the Wattmeter.
- ❑ Release the PTT switch.
- ❑ Rotate the Main Tuning Dial knob to select the alignment parameter "d12 iAL" then rotate the [SUB(VFO-B)] knob so that the VFO-B frequency display shows "0020."
- ❑ Rotate the [MIC] knob to the fully counter-clockwise position.
- ❑ Press the PTT switch, then gently rotate the [MIC] knob to the fully clockwise position.
- ❑ Rotate the [SUB(VFO-B)] knob for 115 W (+5W/-0W) on the Wattmeter.
- ❑ Release the PTT switch.
- ❑ Rotate the Main Tuning Dial knob to select the alignment parameter "d13 iAL" then rotate the [SUB(VFO-B)] knob so that the VFO-B frequency display shows "0020."
- ❑ Rotate the [MIC] knob to the fully counter-clockwise position.
- ❑ Press the PTT switch, then gently rotate the [MIC] knob to the fully clockwise position.
- ❑ Rotate the [SUB(VFO-B)] knob for 115 W (+5W/-0W) on the Wattmeter.
- ❑ Release the PTT switch.
- ❑ Rotate the Main Tuning Dial knob to select the alignment parameter "d14 iAL" then rotate the [SUB(VFO-B)] knob so that the VFO-B frequency display shows "0020."
- ❑ Rotate the [MIC] knob to the fully counter-clockwise position.
- ❑ Press the PTT switch, then gently rotate the [MIC] knob to the fully clockwise position.
- ❑ Rotate the [SUB(VFO-B)] knob for 115 W (+5W/-0W) on the Wattmeter.
- ❑ Release the PTT switch.

# Alignment

- ❑ Rotate the Main Tuning Dial knob to select the alignment parameter “d15 iAL” then rotate the [SUB(VFO-B)] knob so that the VFO-B frequency display shows “0020.”
- ❑ Rotate the [MIC] knob to the fully counter-clockwise position.
- ❑ Press the PTT switch, then gently rotate the [MIC] knob to the fully clockwise position.
- ❑ Rotate the [SUB(VFO-B)] knob for 100 W (+5W/-0W) on the Wattmeter, then rotate the [SUB(VFO-B)] knob so that the VFO-B frequency indication “10” increase.
- ❑ Release the PTT switch.
- ❑ Rotate the Main Tuning Dial knob to select the alignment parameter “d16 iAL” then rotate the [SUB(VFO-B)] knob so that the VFO-B frequency display shows “0020.”
- ❑ Rotate the [MIC] knob to the fully counter-clockwise position.
- ❑ Press the PTT switch, then gently rotate the [MIC] knob to the fully clockwise position.
- ❑ Rotate the [SUB(VFO-B)] knob for 100 W (+5W/-0W) on the Wattmeter, then rotate the [SUB(VFO-B)] knob so that the VFO-B frequency indication “10” increase.
- ❑ Release the PTT switch.
- ❑ Rotate the Main Tuning Dial knob to select the alignment parameter “d17 iAL” then rotate the [SUB(VFO-B)] knob so that the VFO-B frequency display shows “0020.”
- ❑ Rotate the [MIC] knob to the fully counter-clockwise position.
- ❑ Press the PTT switch, then gently rotate the [MIC] knob to the fully clockwise position.
- ❑ Rotate the [SUB(VFO-B)] knob for 100 W (+5W/-0W) on the Wattmeter, then rotate the [SUB(VFO-B)] knob so that the VFO-B frequency indication “10” increase.
- ❑ Release the PTT switch.
- ❑ Press and hold in the [MENU] button for 2 seconds to save the new setting and exit from the alignment mode.

## Power Adjustment

- ❑ Connect the 50-Ohm Dummy Load and Wattmeter to the “ANT 1” jack.
- ❑ Rotate the [RF PWR] knob to fully clockwise.
- ❑ Set the Main Band (VFO-A) frequency to 14.200 MHz in the CW mode.
- ❑ Press and hold in the [1(1.8)], [2(3.5)], and [3(7)] keys, while turning the radio on, to enter the alignment mode.
- ❑ Rotate the Main Tuning Dial knob to select the alignment parameter “d22AP2h.”
- ❑ Rotate the [SUB(VFO-B)] knob so that the VFO-B frequency display shows “0.”
- ❑ Press the PTT switch, then rotate the [SUB(VFO-B)] knob for 100 W (+5 W/-0 W) on the Wattmeter.
- ❑ Release the PTT switch.
- ❑ Press and hold in the [MENU] button for 2 seconds to save the new setting and exit from the alignment mode.

## ALC Meter Adjustment

- ❑ Connect the 50-Ohm Dummy Load and Wattmeter to the “ANT 1” jack.
- ❑ Connect the Audio Generator to pin 8 of the MIC jack (pin 7: GND), then set the output level to +0 mV @1 kHz.
- ❑ Set the Main Band (VFO-A) frequency to 14.200 MHz in the USB mode.
- ❑ Rotate the [MIC] knob to the 12 o’clock position, and rotate the [RF PWR] knob to the fully clockwise position.
- ❑ Press and hold in the [1(1.8)], [2(3.5)], and [3(7)] keys, while turning the radio on, to enter the alignment mode.
- ❑ Rotate the Main Tuning Dial knob to select the alignment parameter “d50 ALC.”
- ❑ Press the PTT switch, then adjust the Audio Generator output level to the position where the ALC meter just starts to deflect.
- ❑ Release the PTT switch, then increase the Audio Generator output level for “9 dB.”
- ❑ Press the [ENT] key, while pressing and holding in the PTT switch, then rotate the [SUB(VFO-B)] knob for maximum deflection on the ALC meter zone (S9+10dB).
- ❑ Release the PTT switch, then press and hold in the [MENU] button for 2 seconds to save the new setting and exit from the alignment mode.

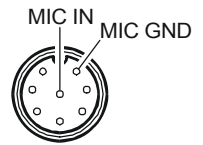

## TX Output Power/PO Meter/TXG Adjustment

- ❑ Referring to table below, tune the transceiver to each frequency listed.

BAND	VFO-A FREQUENCY	MODE
1.8 MHz Band	1.820 MHz	CW
3.5 MHz Band	3.570 MHz	CW
7 MHz Band	7.050 MHz	CW
10 MHz Band	10.100 MHz	CW
14 MHz Band	14.200 MHz	CW
18 MHz Band	18.100 MHz	CW
21 MHz Band	21.200 MHz	CW
24.5 MHz Band	24.900 MHz	CW
28 MHz Band	29.690 MHz	CW
50 MHz Band	53.900 MHz	CW

- ❑ Connect the 50-Ohm Dummy Load and Wattmeter to the “ANT 1” jack.
- ❑ Set the Main Band (VFO-A) frequency to 1.820 MHz in the CW mode.
- ❑ Press and hold in the [1(1.8)], [2(3.5)], and [3(7)] keys, while turning the radio on, to enter the alignment mode.
- ❑ Rotate the Main Dial knob to select the alignment parameter “d18AP2h.”
- ❑ Rotate the [SUB(VFO-B)] knob so that the VFO-B frequency display shows “0.”
- ❑ Rotate the [VRF] knob for 100 W on the PO meter.
- ❑ Press the PTT switch, then rotate the [SUB(VFO-B)] knob for 100 W on the Wattmeter.
- ❑ Rotate the [CLAR] knob so that the Sub S-meter deflects “S-9.”
- ❑ Release the PTT switch.
- ❑ Perform the same procedures for the Alignment Menus “d18bP1h” through “d27EP10,” per the chart at the right.

## AM-TXG Adjustment

- ❑ Connect the 50-Ohm Dummy Load and Wattmeter to the “ANT 1” jack.
- ❑ Rotate the [RF PWR] knob to fully clockwise.
- ❑ Set the Main Band (VFO-A) frequency to 14.200 MHz in the AM mode.
- ❑ Press and hold in the [1(1.8)], [2(3.5)], and [3(7)] keys, while turning the radio on, to enter the alignment mode.
- ❑ Rotate the Main Tuning Dial knob to select the alignment parameter “d29 tCA.”
- ❑ Rotate the [SUB(VFO-B)] knob so that the VFO-B frequency display shows “0.”
- ❑ Press the PTT switch without microphone input, then rotate the [SUB(VFO-B)] knob for 35 W ( $\pm 5$  W) on the Wattmeter.
- ❑ Release the PTT switch.
- ❑ Press and hold in the [MENU] button for 2 seconds to save the new setting and exit from the alignment mode.

ALIGNMENT MENU	VFO-B FREQ. DISPLAY	PO METER	WATTMETER	SUB S-METER
d18bP1h	0	50 W	50 W	S-9
d18cP50	0	20 W	20 W	S-9
d18dP20	0	10 W	10 W	S-9
d18EP10	0	5 W	5 W	S-9
d19AP2h	0	100 W	100 W	S-9
d19bP1h	0	50 W	50 W	S-9
d19cP50	0	20 W	20 W	S-9
d19dP20	0	10 W	10 W	S-9
d20EP10	0	5 W	5 W	S-9
d20AP2h	0	100 W	100 W	S-9
d20bP1h	0	50 W	50 W	S-9
d20cP50	0	20 W	20 W	S-9
d20dP20	0	10 W	10 W	S-9
d20EP10	0	5 W	5 W	S-9
d21AP2h	0	100 W	100 W	S-9
d21bP1h	0	50 W	50 W	S-9
d21cP50	0	20 W	20 W	S-9
d21dP20	0	10 W	10 W	S-9
d21EP10	0	5 W	5 W	S-9
d22AP2h	0	100 W	100 W	S-9
d22bP1h	0	50 W	50 W	S-9
d22cP50	0	20 W	20 W	S-9
d22dP20	0	10 W	10 W	S-9
d22EP10	0	5 W	5 W	S-9
d23AP2h	0	100 W	100 W	S-9
d23bP1h	0	50 W	50 W	S-9
d23cP50	0	20 W	20 W	S-9
d23dP20	0	10 W	10 W	S-9
d23EP10	0	5 W	5 W	S-9
d24AP2h	0	100 W	100 W	S-9
d24bP1h	0	50 W	50 W	S-9
d24cP50	0	20 W	20 W	S-9
d24dP20	0	10 W	10 W	S-9
d24EP10	0	5 W	5 W	S-9
d25AP2h	0	100 W	100 W	S-9
d25bP1h	0	50 W	50 W	S-9
d25cP50	0	20 W	20 W	S-9
d25dP20	0	10 W	10 W	S-9
d25EP10	0	5 W	5 W	S-9
d26AP2h	0	100 W	100 W	S-9
d26bP1h	0	50 W	50 W	S-9
d26cP50	0	20 W	20 W	S-9
d26dP20	0	10 W	10 W	S-9
d26EP10	0	5 W	5 W	S-9
d27AP2h	0	100 W	100 W	S-9
d27bP1h	0	50 W	50 W	S-9
d27cP50	0	20 W	20 W	S-9
d27dP20	0	10 W	10 W	S-9
d27EP10	0	5 W	5 W	S-9

# Alignment

## REV-ALC Adjustment

- ❑ Referring to table below, tune the transceiver to each frequency listed.

BAND	VFO-A FREQUENCY	MODE
1.8 MHz Band	1.820 MHz	CW
3.5 MHz Band	3.570 MHz	CW
7 MHz Band	7.050 MHz	CW
10 MHz Band	10.100 MHz	CW
14 MHz Band	14.200 MHz	CW
18 MHz Band	18.100 MHz	CW
21 MHz Band	21.200 MHz	CW
24.5 MHz Band	24.900 MHz	CW
28 MHz Band	29.690 MHz	CW
50 MHz Band	53.900 MHz	CW

- ❑ Connect the 16.6-Ohm Dummy Load and Wattmeter to the “ANT 1” Jack, then set the [METER] switch to “PO” position.
- ❑ Set the MAIN Band (VFO-A) frequency to 1.820 MHz in the CW mode.
- ❑ Press and hold in the [1(1.8)], [2(3.5)], and [3(7)] keys, while turning the radio on, to enter the alignment mode.
- ❑ Rotate the Main Tuning Dial knob to select the alignment parameter “d40 rAC.”
- ❑ Rotate the [SUB(VFO-B)] knob so that the VFO-B frequency display shows “0.”
- ❑ Press the PTT switch, then rotate the [SUB(VFO-B)] knob so that the VFO-B frequency display shows “060.”
- ❑ Release the PTT switch.
- ❑ Perform the same procedures for the Alignment Menu “d40 rAC” through “d49 rAC.”
- ❑ Press and hold in the [MENU] button for 2 seconds to save the new setting and exit from the alignment mode.

## FM MAX Deviation Adjustment

- ❑ Connect the Dummy Load, Wattmeter, and Deviation Meter to the “ANT 1” Jack.
- ❑ Set the Main Band (VFO-A) frequency to 28.700 MHz in the FM mode.
- ❑ Connect the Audio Generator to pin 8 of the MIC jack (pin 7: GND), then set the output level to 10 mV @1 kHz.
- ❑ Press and hold in the [1(1.8)], [2(3.5)], and [3(7)] keys, while turning the radio on, to enter the alignment mode.
- ❑ Rotate the Main Tuning Dial knob to select the alignment parameter “d51 F45.”
- ❑ Press the PTT switch, then rotate the [SUB(VFO-B)] knob for 4.5 kHz ( $\pm 0.2$  kHz) on the Deviation Meter.
- ❑ Release the PTT switch.

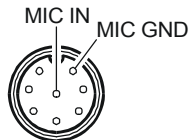

- ❑ Set the Main Band (VFO-A) operating mode to the FM-N mode.
- ❑ Rotate the Main Tuning Dial knob to select the alignment parameter “d52 F23.”
- ❑ Press the PTT switch, then rotate the [SUB(VFO-B)] knob for 2.25 kHz ( $\pm 0.15$  kHz) on the Deviation Meter.
- ❑ Release the PTT switch.
- ❑ Press and hold in the [MENU] button for 2 seconds to save the new setting and exit from the alignment mode.

## COMP Meter Adjustment

- ❑ Press and hold in the [ANT1], [ANT3], and [RX ANT] keys, while turning the radio on, to enter the alignment mode.
- ❑ Rotate the Main Tuning Dial knob to select the alignment parameter “d57 C10,” then rotate the [SUB(VFO-B)] knob for “10 dB” on the COMP meter.
- ❑ Rotate the Main Tuning Dial knob to select the alignment parameter “d58 C20,” then rotate the [SUB(VFO-B)] knob for “20 dB” on the COMP meter.
- ❑ Rotate the Main Tuning Dial knob to select the alignment parameter “d59 C30,” then rotate the [SUB(VFO-B)] knob so that the COMP meter deflects to full scale.
- ❑ Press and hold in the [MNU] key for 2 seconds to exit from the alignment mode.

## SWR Meter Adjustment

- ❑ Switch the external display to “SWR Monitor” page.
- ❑ Connect the 50-Ohm Dummy Load and Wattmeter to the “ANT 1” Jack, then set the [METER] switch to the “SWR” position.
- ❑ Disconnect the 3-pin plug from J1015 on the MAIN Unit, then apply a 4.2 V DC voltage to pin 2 of J1015, and 2.1 V DC to pin 3 of J1015.
- ❑ Press and hold in the [1(1.8)], [2(3.5)], and [3(7)] keys, while turning the radio on, to enter the alignment mode.
- ❑ Rotate the Main Tuning Dial knob to select the alignment parameter “d53c530.”
- ❑ Press the PTT switch, then rotate the [VRF] knob so that the SWR meter (on the external display) reading is “3.0.” The SWR meter reading (3.0) is broad (few points). Therefore, set the [VRF] knob to the center of this broad range.

- ❑ Rotate the [SUB(VFO-B)] knob so that the SWR meter (on the front panel) reading is “3.0.”
- ❑ Release the PTT switch.
- ❑ Perform the same procedures for the Alignment Menus “d54c530” and “d55c530.”
- ❑ Apply a 4.2 V DC voltage to pin 2 of J1015, and 1.4 V DC to pin 3 of J1015.
- ❑ Rotate the Main Tuning Dial knob to select the alignment parameter “d53b520.”
- ❑ Press the PTT switch, then rotate the [SUB(VFO-B)] knob so that the SWR meter (on the front panel) reading is “2.0.”
- ❑ Release the PTT switch.
- ❑ Perform the same procedures for the Alignment Menus “d54b520” and “d55b520.”
- ❑ Apply a 4.2 V DC voltage to pin 2 of J1015, and 0.84 V DC to pin 3 of J1015.
- ❑ Rotate the Main Tuning Dial knob to select the alignment parameter “d53A515.”
- ❑ Press the PTT switch, then rotate the [SUB(VFO-B)] knob so that the SWR meter (on the front panel) reading is “1.5.”
- ❑ Release the PTT switch.
- ❑ Perform the same procedures for the Alignment Menus “d54A515” and “d55A515.”
- ❑ Press and hold in the [MENU] button for 2 seconds to save the new setting and exit from the alignment mode.

# *Alignment*

*Note*